

| Position | Amount | Type number | Description                              | PG |
|----------|--------|-------------|--|----|
| 1        | 1      | 1382693309  | EXTENSION PLATE BL 2,00X572X832 TKHS315M | 40 |
| 2        | 41     | 6209110995  | Flange nut                               | 10 |
| 3        | 23     | 141151340   | Washer                                   | 10 |
| 4        | 4      | 1395200611  | BEARING BOLT                             | 14 |
| 5        | 2      | 1382678121  | SUPPORT BL 1,00X70X764,5 TVL             | 26 |
| 6        | 2      | 6132685086  | HEX.SOCKET COUNTERS.HEAD SCREW M 6X10 VE | 10 |
| 7        | 25     | 6209114230  | Flange nut                               | 10 |
| 8        | 2      | 1381693917  | PLUG RD20/15-17X11,5                     | 11 |
| 9        | 2      | 1382693828  | BRACKET, PRESSURE ROLLER BD 2,99X64X213  | 21 |
| 10       | 1      | 1485693889  | CROSSCUT FENCE GUIDE ROD RD 20X2X820 TKH | 27 |
| 11       | 26     | 6103001178  | Hex head screw                           | 10 |
| 12       | 2      | 1382693856  | ANGLE BRACKET BL 2,50X30X116             | 23 |
| 13       | 2      | 141123420   | Self-tapp. counters. screw               | 10 |
| 14       | 1      | 2391091725  | End piece                                | 12 |
| 15       | 1      | 1391200145  | PLUG QUERANSCHLAG                        | 14 |
| 16       | 1      | 1393005315  | FENCE EXTRUSION 300 MM                   | 25 |
| 17       | 2      | 6110076574  | Truss head screw                         | 10 |
| 18       | 21     | 141151940   | Washer                                   | 10 |
| 19       | 4      | 6241125058  | Knurled nut                              | 12 |
| 20       | 1      | 7001144191  | STARKNOB SCREW M 8X23 (DIN 933) VERZINKT | 13 |
| 21       | 1      | 1390018033  | STOP RULE                                | 25 |
| 22       | 4      | 6172032905  | CROSS REC'D PAN HEAD TAP.SCREW ST 3,5X16 | 10 |
| 23       | 1      | 6174155800  | Self-tapp. counters. screw               | 10 |
| 24       | 1      | 1382409775  | STOP RULE, LOWER BL 2,99 (N.ZCHNG)       | 27 |
| 25       | 1      | 1381410559  | GLIDE PIECE                              | 12 |
| 26       | 1      | 6264139374  | CAGE NUT M 8 BLECHSTÄRKE 1,8-3,2         | 12 |
| 27       | 6      | 141130100   | Hexagonal nut                            | 10 |
| 28       | 12     | 6103015675  | Hex head screw                           | 10 |
| 29       | 2      | 1381409879  | GUIDE PIECE QUERANSCHLAG                 | 14 |
| 30       | 1      | 1010017811  | FENCE EXTRUSION 300 MM                   | 27 |
| 32       | 6      | 6130019585  | SLOTTED FLAT HEAD SCREW M 6X20 VERZ.     | 10 |
| 33       | 1      | 1382693287  | TABLE PANEL BL 2,00X668X868 TKHS315M     | 39 |
| 34       | 1      | 1010186710  | MITRE FENCE ASSEMBLY ET                  | 42 |
| 35       | 1      | 1482693691  | CHIP CASE GUIDE PANEL BL 2,00X163X440 HI | 30 |
| 36       | 1      | 1482693179  | BRACKET FL 25X10X65 TKHS315M             | 25 |
| 37       | 7      | 6202002291  | HEXAGON NUT, PREV. TORQUE TYPE           | 10 |
| 38       | 7      | 141114860   | Hexagon head screw                       | 12 |
| 39       | 1      | 1381406667  | REMOVABLE TABLE SECTION                  | 24 |
| 40       | 1      | 1382721906  | HOSE CARRIER TKHS 315 D&D ET             | 14 |
| 41       | 2      | 1482408962  | CAM PLATE BL 2,99XRD25/RDI 6,5           | 10 |
| 42       | 1      | 1382721892  | GUARD PLATE TKHS 315 D&D ET              | 18 |

|    |   |            |  |    |
|----|---|------------|--|----|
| 43 | 1 | 6172028215 | Fillister head screw                     | 10 |
| 44 | 1 | 141150110  | Washer                                   | 10 |
| 45 | 1 | 1142694260 | SCALE 0,30X13X413 0,00-38,80 CM          | 18 |
| 46 | 1 | 7854158010 | CORRUGATED HOSE RDI 36,2X1500 PROFIL D   | 27 |
| 47 | 1 | 1010692594 | SAW BLADE GUARD W/SUCTION PORT TKHS315M  | 22 |
| 48 | 1 | 1142694464 | ARBOR TILT SCALE 0,25X13 47-0 GRAD       | 16 |
| 49 | 1 | 1482693683 | CHIP CASE GUIDE PANEL BL 2,00X163X440 VO | 30 |
| 50 | 7 | 6202002305 | HEXAGON NUT, PREV. TORQUE TYPE           | 10 |
| 51 | 2 | 1485412910 | Spacer sleeve                            | 12 |
| 52 | 2 | 6110000659 | Truss head screw                         | 10 |
| 53 | 1 | 1383694279 | FENCE GUIDE EXTRUSION 463 MM TKHS315M    | 28 |
| 54 | 3 | 6110031325 | Truss head screw                         | 10 |
| 55 | 1 | 1485693161 | SPACER SLEEVE RDI 12X7                   | 12 |
| 56 | 1 | 1383680260 | Angle,KGT 501                            | 30 |
| 57 | 1 | 1383158458 | RIP FENCE EXTRUSION 570 MM               | 31 |
| 58 | 1 | 1382680053 | Locking element                          | 33 |
| 59 | 2 | 6132087995 | Countersunk screw                        | 10 |
| 60 | 1 | 7016050711 | STARLOCK                                 | 10 |
| 61 | 1 | 1392205620 | Clamping plate,BL 1X26X91,5              | 12 |
| 62 | 1 | 6632111175 | BOLT WITH HEAD                           | 13 |
| 63 | 1 | 2390205484 | Cam lock lever                           | 19 |
| 64 | 1 | 1010680243 | Parallel guide,KGT501/TKHS               | 44 |
| 70 | 1 | 1010692586 | WHEEL SET TKHS315M GUMMIBEREIFT          | 29 |
| 71 | 4 | 1382693597 | LEG BL 1,5X142X842 TKHS315M              | 29 |
| 72 | 2 | 1382407080 | STANCHION BL 1,5X118X844 LANG            | 23 |
| 73 | 2 | 1382693813 | STANCHION BL 1,5X118X644 KURZ / TKHS315M | 23 |
| 74 | 1 | 1394201630 | Push stick                               | 19 |
| 75 | 1 | 1392038481 | OPEN END SPANNER BL 3X43/15X145 SW 19X14 | 15 |
| 76 | 1 | 1388680470 | SLIDING HANDLE RED                       | 31 |
| 77 | 1 | 1492102829 | Key                                      | 20 |
| 78 | 1 | 1010689330 | HANDLE BAR (PAIR) TKHS315C/M             | 20 |
| 79 | 2 | 6123612815 | RAISED CHEESE HEAD SCREW                 | 10 |
| 80 | 2 | 141150120  | Washer                                   | 10 |
| 81 | 4 | 6172001830 | Fillister head screw                     | 10 |
| 82 | 1 | 1381689227 | DUST EXTRACTION PORT TKHS315C/M          | 19 |
| 83 | 1 | 1382694160 | COVER BL 1,50X116X613,5 TKHS315M         | 27 |
| 84 | 2 | 141113840  | Cap screw                                | 12 |
| 85 | 1 | 1382694119 | CHIPCASE BL 2,00X350X600 TKHS315M        | 42 |
| 86 | 1 | 6127059207 | Cap screw                                | 10 |
| 87 | 1 | 1382693643 | SPLITTING BLADE TKHS315M                 | 25 |
| 88 | 1 | 1382213749 | PRESSURE PLATE BL 2,99X80X60             | 12 |
| 89 | 1 | 6209002432 | FLANGE NUT                               | 13 |

|     |   |            |  |    |
|-----|---|------------|--|----|
| 90  | 1 | 1382407110 | SLIDE PLATE BL 1,5X48X137,5              | 12 |
| 94  | 1 | 1380693255 | RIVING KNIFE CARRIER VORNE TKHS315M      | 22 |
| 95  | 1 | 1142694472 | SCALE 0,25X20X114 0-85 MM                | 15 |
| 96  | 2 | 1380729756 | SWIVEL SEGMENT TKHS-M                    | 16 |
| 97  | 4 | 6103001135 | Hex head screw                           | 10 |
| 98  | 8 | 6305002486 | Washer                                   | 10 |
| 100 | 1 | 141110320  | Hexagon head screw                       | 12 |
| 101 | 1 | 6110019007 | CUP SQUARE NECK SCREW M 12X50 VERZ.      | 12 |
| 102 | 1 | 1382721876 | RIVING KNIFE CARRIER PLATE TKHS 315 D&D  | 24 |
| 103 | 3 | 1482721857 | ANGLE BRACKET TKHS 315 D&D ET            | 20 |
| 104 | 2 | 1482721849 | ANGLE BRACKET TKHS 315 D&D ET            | 20 |
| 105 | 1 | 1382721868 | POINTER, BLADE TILT TKHS 315 D&D E       | 16 |
| 106 | 1 | 6123022619 | RAISED CHEESE HEAD SCREW                 | 10 |
| 107 | 1 | 2391203523 | POINTER RAL 3000-3003                    | 10 |
| 108 | 1 | 141130930  | Hexagonal lock nut                       | 10 |
| 109 | 1 | 1382721884 | MOTOR PLATE TKHS 315 D&D ET              | 24 |
| 110 | 1 | 7053081619 | CUP SPRING                               | 10 |
| 111 | 1 | 6110000608 | CUP SQUARE NECK SCREW                    | 10 |
| 112 | 4 | 6132661454 | HEX.SOCKET COUNTERS.HEAD SCREW           | 10 |
| 113 | 1 | 1383694139 | TOOTHED RACK 624 MM TKHS315M             | 31 |
| 114 | 1 | 1391200390 | Selector wheel                           | 18 |
| 116 | 1 | 6205032396 | HEXAGON THIN NUT                         | 10 |
| 117 | 1 | 1382722031 | CHIP CASE TKHS315 D&D                    | 37 |
| 118 | 1 | 1010689240 | BLADE COLLAR ASSEMBLY ET                 | 26 |
| 120 | 1 | 1482681987 | ANGLE POINTER BL 1,50X10X21,5 KGS303     | 12 |
| 121 | 8 | 141150130  | Washer                                   | 10 |
| 122 | 1 | 7005155791 | WING NUT M 6                             | 13 |
| 123 | 1 | 6103722010 | HEXAGON HEAD SCREW M 12-10 207LANG VER   | 17 |
| 127 | 1 | 1010726545 | TERMINAL BOX ASSEMBLY 2,5 - 3,1 KW D&D   | 24 |
| 128 | 1 | 6442694557 | SPACER SLEEVE RD 26,9/20,5X7 TKHS315M    | 16 |
| 129 | 1 | 6721041830 | FEATHER KE A 6X4X50                      | 10 |
| 131 | 1 | 1382694038 | HEIGHT-ADJUSTMENT BL 2,99 TKHS315M       | 29 |
| 133 | 1 | 7100010180 | DEEP GROOVE BALL BEARING                 | 18 |
| 136 | 1 | 1388721916 | BEARING SEA TKHS 315 D&D ET              | 14 |
| 137 | 1 | 6260721923 | TENSION NU TKHS 315 D&D ET               | 13 |
| 138 | 1 | 1382411257 | HANDWHEEL BL 2X RD 165                   | 20 |
| 139 | 2 | 6305002508 | WASHER B 13 VERZ.                        | 10 |
| 141 | 1 | 6121112564 | HEXAGON SOCKET HEAD CAP SCREW            | 10 |
| 142 | 1 | 7004017433 | TURNING TANG                             | 14 |
| 143 | 1 | 1010689259 | FAN WING+FAN COVER ET                    | 22 |
| 145 | 2 | 6103001356 | HEXAGON HEAD SCREW M 6X16 VERZ.FLECKBESC | 10 |
| 146 | 1 | 1382694690 | SWITCH PLATE BL 2,00X108X135 TKHS315M    | 25 |

|     |   |            |   |    |
|-----|---|------------|---|----|
| 147 | 1 | 8131694947 | SWITCH SSK 2,50WNB 230/1/50 ET          | 41 |
| 148 | 3 | 6132087995 | Countersunk screw                       | 10 |
| 149 | 1 | 8050011810 | Condenser                               | 27 |
| 150 | 1 | 1010693345 | MOTOR, CIRCULAR SAW BENCH T 2,50 WNB 23 | 62 |
| 155 | 1 | 1010702140 | HANDWHEEL KPL. TKHS315M                 | 24 |

toolspareparts.com.au

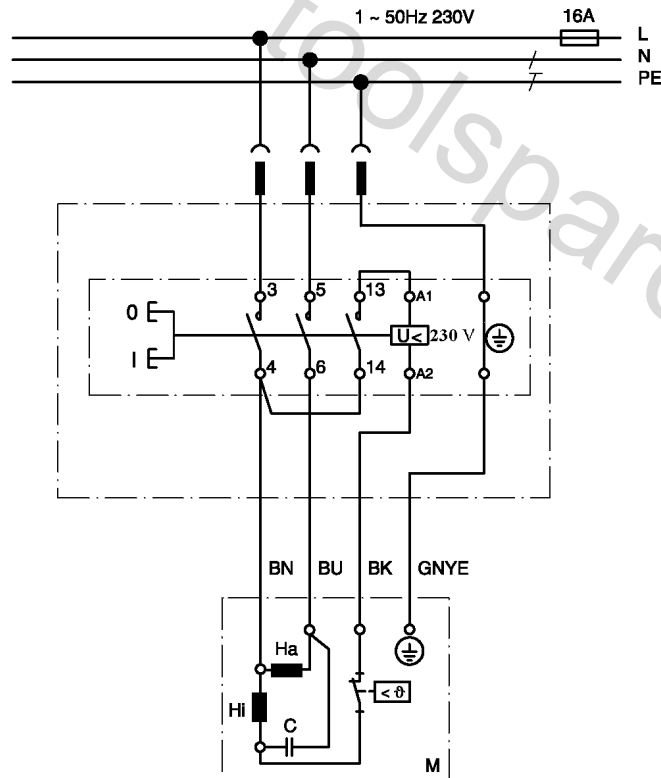

|   | Bedeutung der Kurzzeichen | Meaning of the symbols              | Interprétation des symboles |
|---|---------------------------|-------------------------------------|-----------------------------|
| B | Stecker                   | plug                                | fiche                       |
| C | Kondensator               | condenser                           | condensateur                |
| D | Funktentstördrossel       | interference suppression inductance | inductance d'antiparasitage |
| E | Elektronik-Baustein       | electronic unit                     | unité électronique          |
| I | Induktionsspule           | induction coil                      | bobine d'inductance         |
| K | Klemme                    | terminal                            | borne                       |
| L | Licht                     | light                               | lumière                     |
| M | Motor                     | motor                               | moteur                      |
| O | Überlastschutz            | overload cut-out                    | déclencheur de surintensité |
| R | Drehrichtungsumschalter   | reversing switch                    | commutateur droite-gauche   |
| S | Schalter                  | switch                              | interrupteur                |
| U | Umschalter                | change-over switch                  | commutateur                 |
| X | Elektronik-Element        | electronic element                  | élément électronique        |

|      | Litzenfarben | Colour of strands | Couleur des cordons |
|------|--------------|-------------------|---------------------|
| BK   | schwarz      | black             | noir                |
| WH   | weiß         | white             | blanc               |
| BU   | blau         | blue              | bleu                |
| YE   | gelb         | yellow            | jaune               |
| RD   | rot          | red               | rouge               |
| TR   | transparent  | transparent       | transparent         |
| BN   | braun        | brown             | brun                |
| GY   | grau         | grey              | gris                |
| GNYE | grün-gelb    | green-yellow      | vert-jaune          |
| BKWH | schwarz-weiß | black-white       | noir-blanc          |
| GN   | grün         | green             | vert                |
| OG   | orange       | orange            | orange              |
| VT   | violett      | violet            | violet              |
| TQ   | türkis       | turquoise         | turquoise           |